



Cryogenic Application Guide

Quality flow control products paired with expert advice.



- GLOBE VALVES
- GATE VALVES
- CHECK VALVES
- RELIEF VALVES
- HIGH PRESSURE VALVES
- NEEDLE VALVES
- DIVERTERS
- REGULATORS
- MANIFOLDS
- CYLINDER EQUIPMENT

You do not thrive for more than 100 years because you are lucky.

It takes quality products, constant innovation, and above all a dedication to the customer.

From a pioneer in the development of oxygen regulators to a global leader delivering a comprehensive line of flow control and safety products, RegO has always kept our customers' interests first.

Quality matters. Industrial gas applications have no room for leaks. That is why we design and manufacture in the U.S., test 100% of our products, and can offer a 10-year warranty. RegO products offer performance you can rely on.

Innovative products, processes and people. We invest in technology and training to deliver flow control products designed to reduce your maintenance and replacement costs, and ensure an efficient, safe work flow.

When our customers thrive, we do too. Our experienced team can provide technical support and design assistance. We are here to help in any way, every day.



Quality materials, innovative, long-lasting design and operational excellence are built into every product we manufacture. That is how we can offer a 10-year product warranty—double that of other companies.



Designed, manufactured and 100% tested in the USA. Our four state-of-the-art facilities build the products that are most critical to your application.

Contents

Air separation unit (ASU) products	3
Bulk tank storage	4
Transport trailers	6
Microbulk tank storage	8
Liquid cylinders	10
Liquid cryogenic delivery systems.....	12
Gas phase regulation stations	13
Electric transformer nitrogen delivery systems.....	14
High pressure gas tube storage and transport.....	15
High and medium pressure manifold and delivery systems.....	16
Gas delivery systems.....	17
Carbon dioxide delivery systems	18
Product certifications.....	19



Air separation unit (ASU) products

24/7 production schedules demand 24/7 toughness

RegO valves, regulators and safety devices are engineered to stand up to the toughest environments and provide years of reduced maintenance and worry-free operation. When you have been designing and manufacturing your own products for more than 100 years, you pay attention to the details—like anti-corrosive, ergonomic hand wheels and leak-proof valves that deliver superior flow rates.



www.regoproducts.com/cryo/

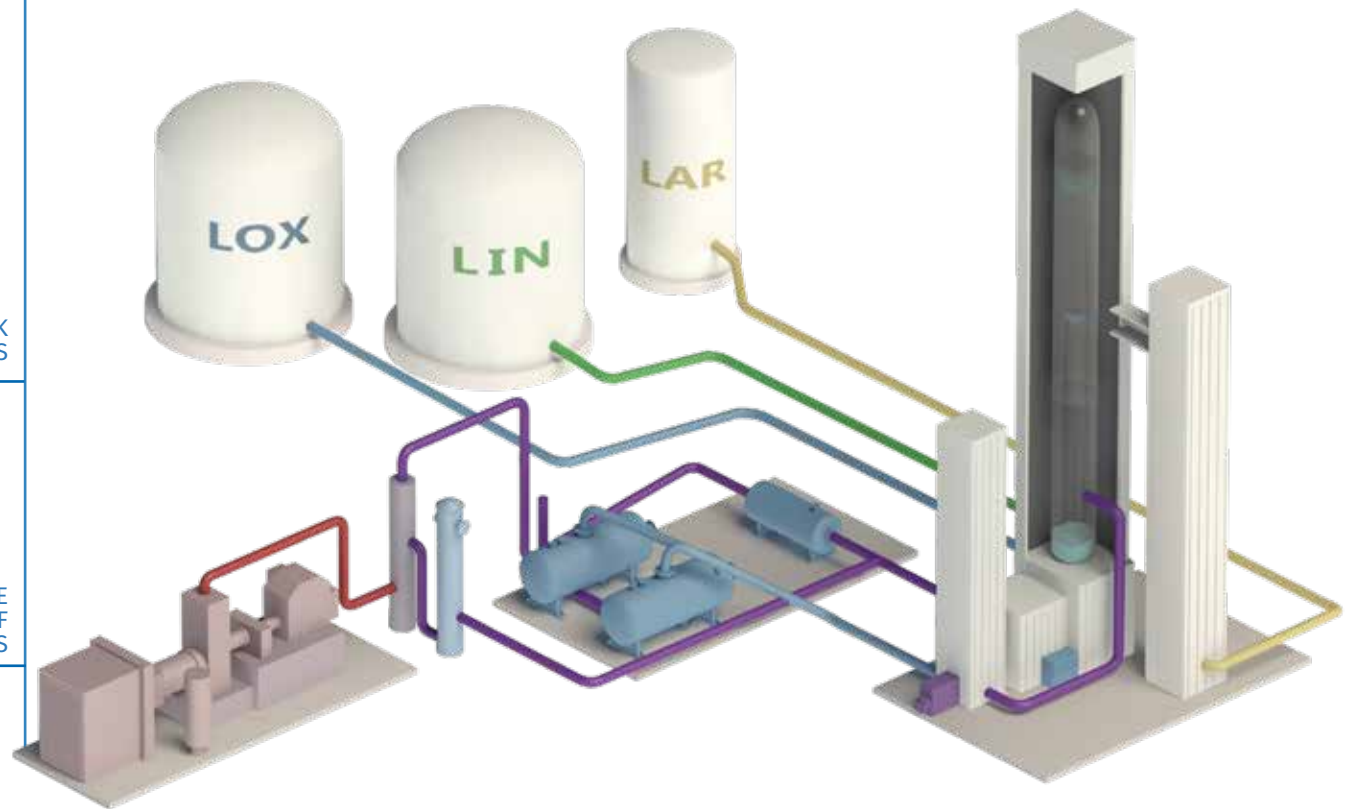

Bulk tank storage

Breadth of line meets depth of knowledge

Combine RegO's industry experience, design assistance and broad product line to build a flow control system that enables maximum efficiency and excellent value for bulk storage applications.

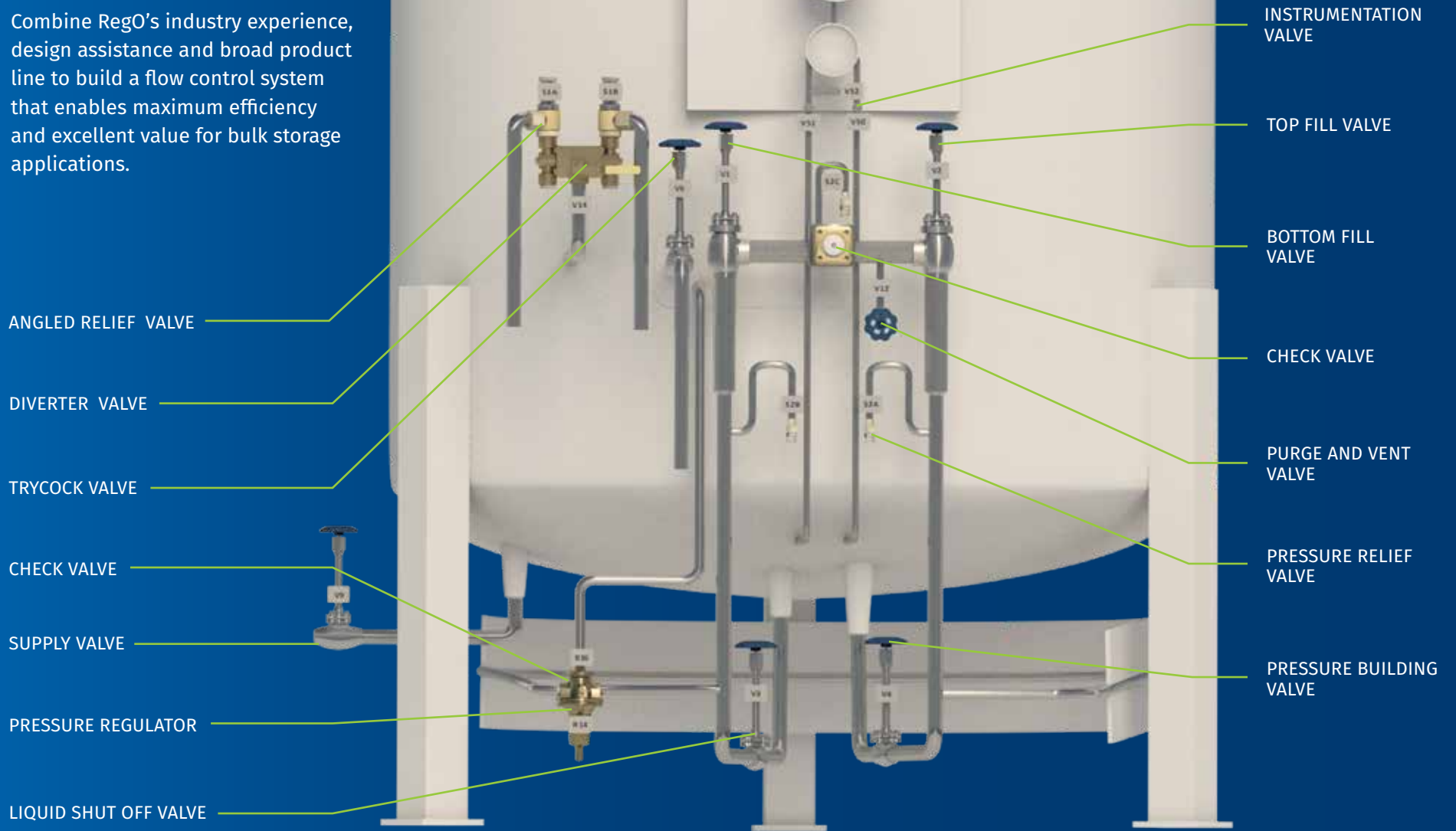

REGO BULK TANK PRODUCTS

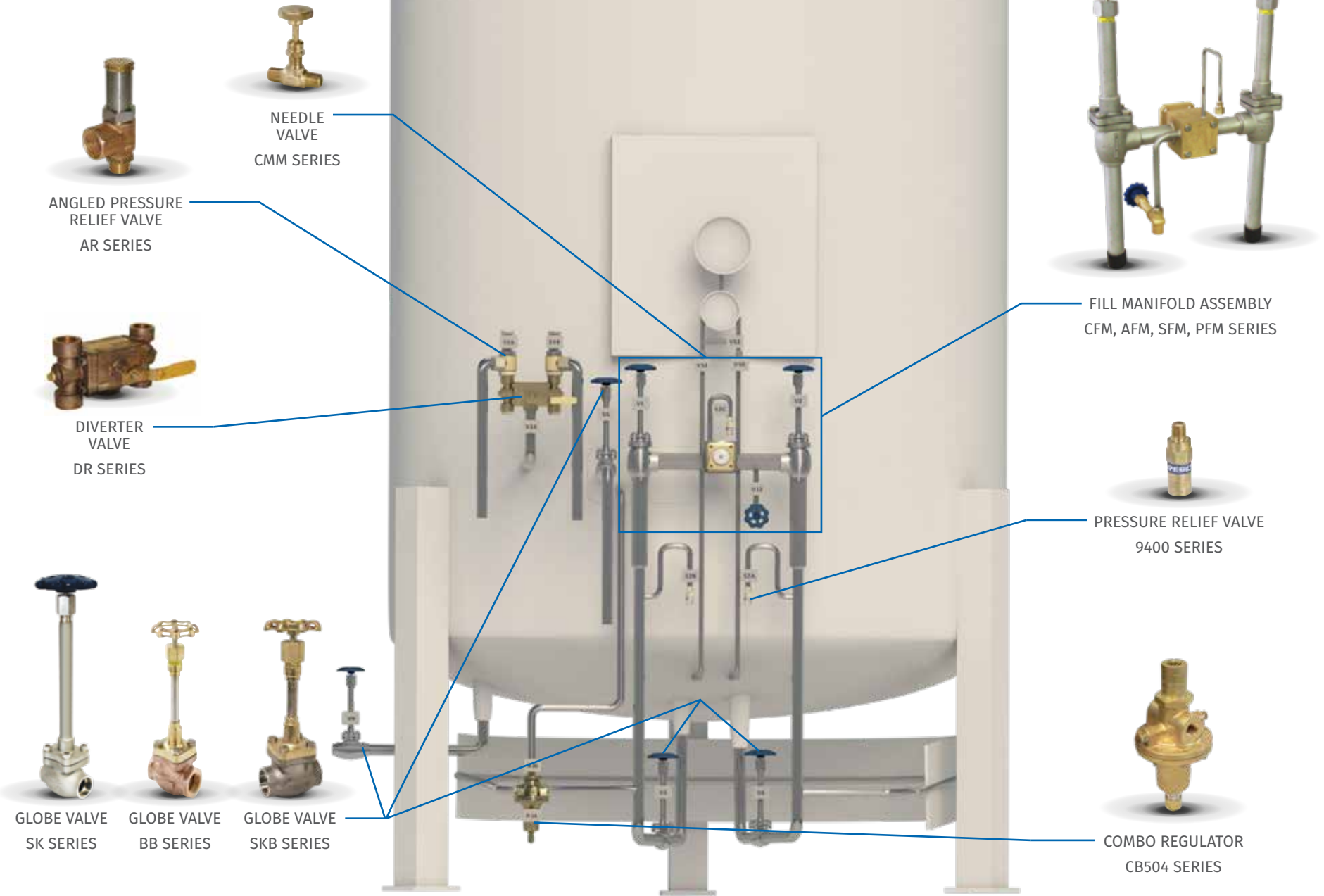

The illustrations in this application guide are intended to inform a professional installer/system designer where our products are generally installed on certain containers or applications. These illustrations are not intended for and must not be used for system design.

Transport trailers

Where safety and reliability intersect

RegO products are meticulously designed, manufactured and 100% tested in the U.S. to deliver quality performance mile after mile. We make loading, transporting and unloading efficient and safe to keep you rolling.

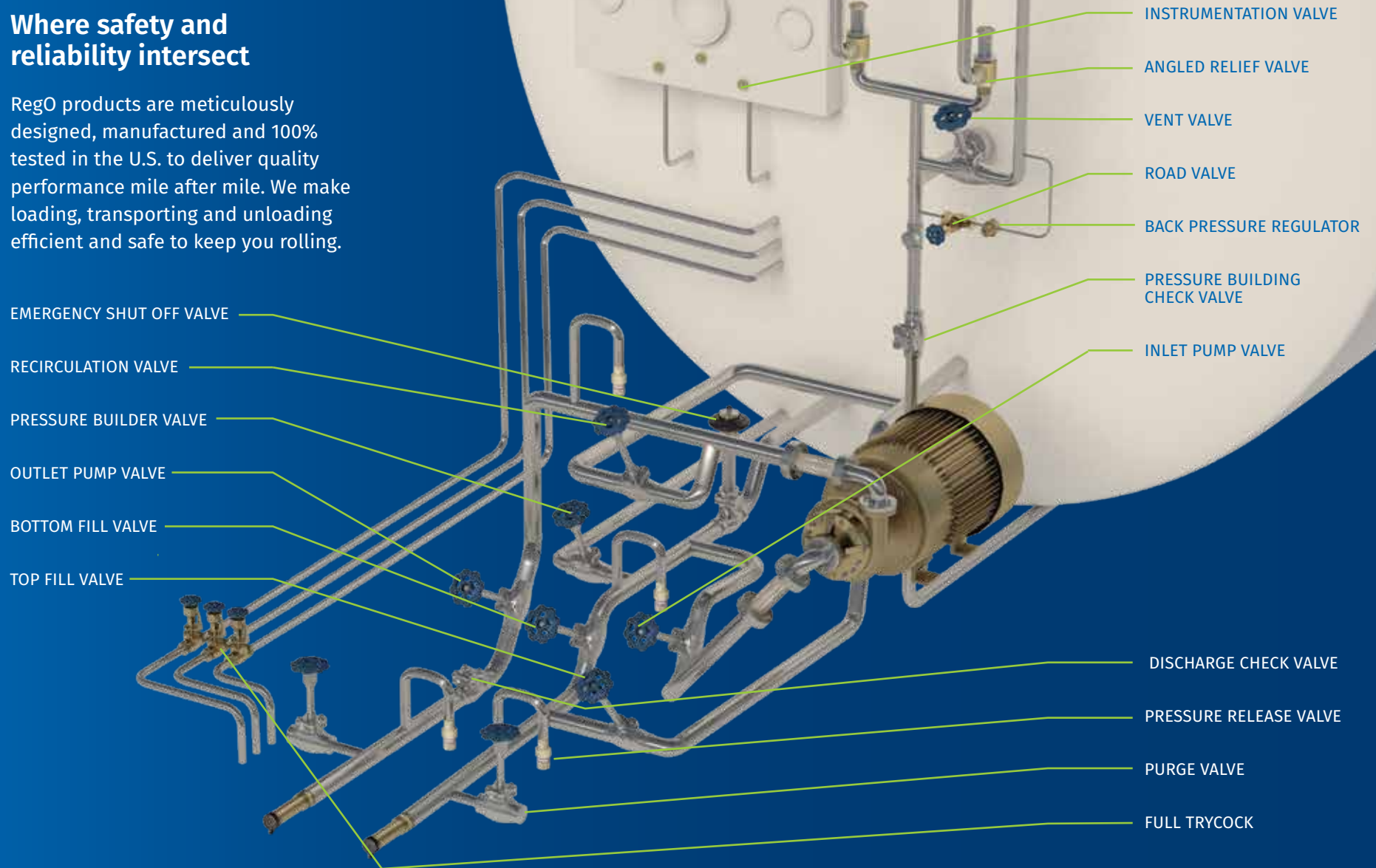

REGO TRAILER PRODUCTS

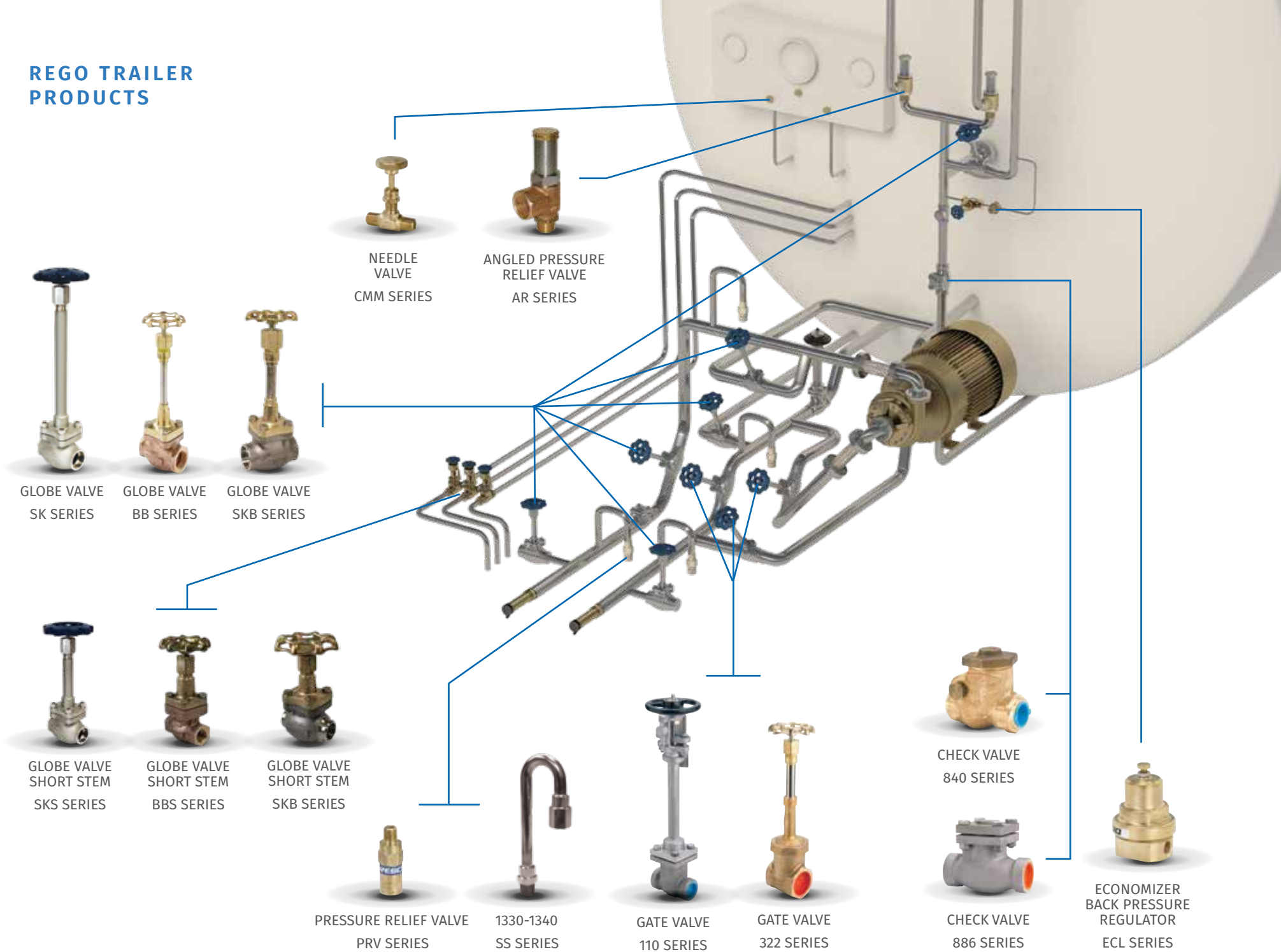

The illustrations in this application guide are intended to inform a professional installer/system designer where our products are generally installed on certain containers or applications. These illustrations are not intended for and must not be used for system design.

Microbulk tank storage

Quality comes in all sizes

Microbulks are ideal for operations that have outgrown cylinder storage solutions or need flexible installation. RegO quality assures a safe, steady supply—no matter what your storage needs are.

INSTRUMENTATION VALVE - GAS

INSTRUMENTATION VALVE - LIQUID

INSTRUMENTATION VALVE - EQUALIZER

RELIEF VALVE

ECONOMIZER ISOLATION VALVE

ECN ECONOMIZER

PB OUTLET VALVE

VENT / FULL TRYCOCK VALVE

LIQUID USE VALVE

HOSE DRAIN VALVE

BOTTOM FILL VALVE

RELIEF VALVE

TOP FILL VALVE

GAS USE VALVE

RELIEF VALVE

AUX GAS VALVE

RELIEF VALVE

PRESSURE BUILDING VALVE

STRAINER

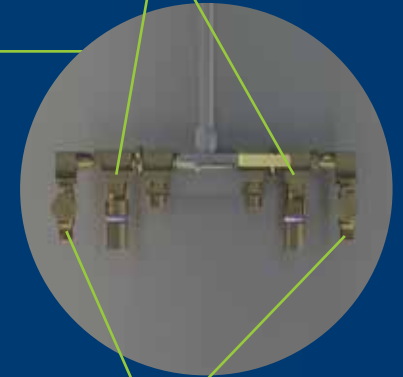
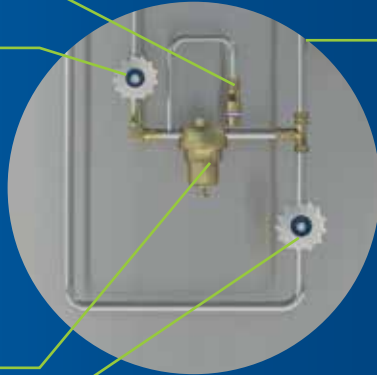

REGO MICROBULK TANK PRODUCTS

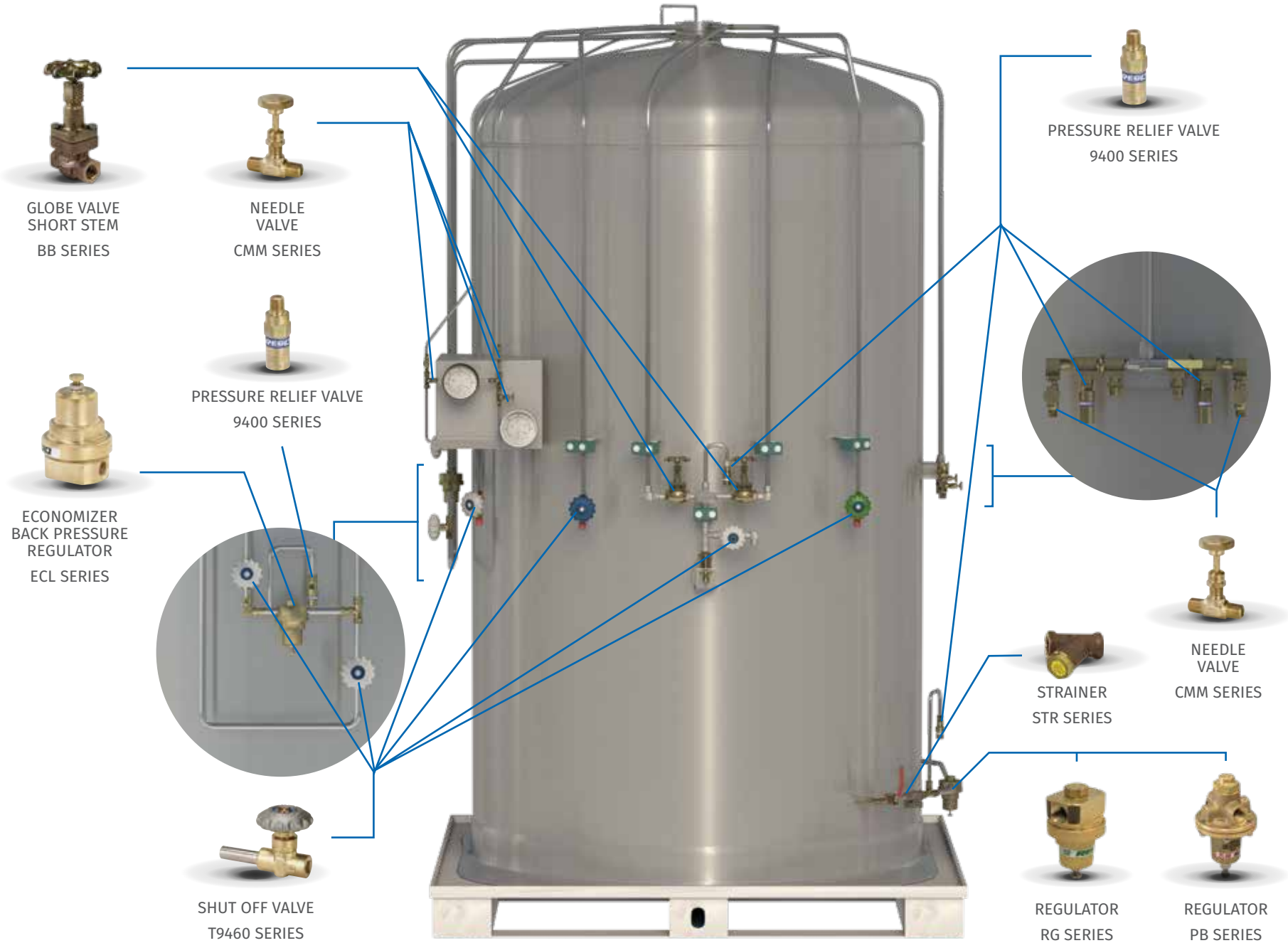

Liquid cylinders

We do not freeze under pressure

Cylinders can take a beating in transport and everyday use. RegO valves are the most widely used in the industry, and deliver a pressure-sealed barrier to avoid freeze-up and maintain constant flow. The robust design prevents maintenance requirements and avoids downtime, while safeguarding against over-torquing for long-lasting operation, with lower operational costs.

Rated for liquid oxygen service per CGA G-4.1.



PRESSURE BUILDING VALVE

LIQUID USE VALVE

ECONOMIZER/ PRESSURE BUILDING REGULATOR

VENT VALVE

PRESSURE RELIEF VALVE

GAS USE VALVE

REGO LIQUID CYLINDER PRODUCTS

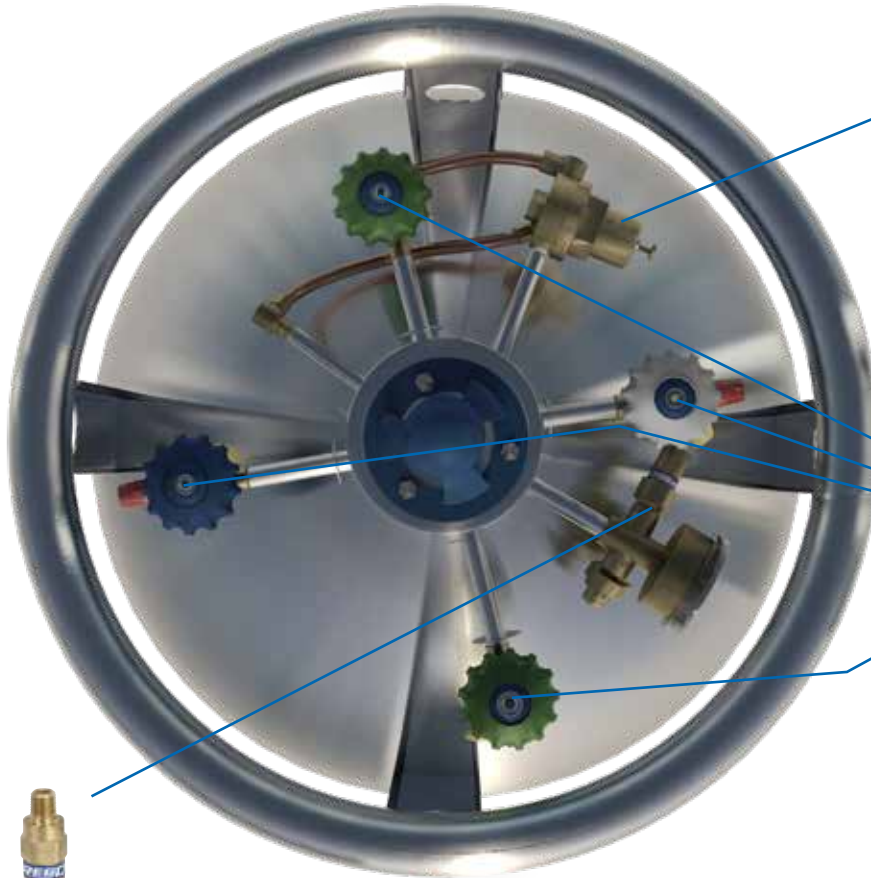

PRESSURE RELIEF VALVE
PRV SERIES

COMBO REGULATOR
CBC/CBH SERIES

SHUT OFF VALVES
T9460 SERIES

SHUT OFF VALVES
T9460 SERIES



Liquid cryogenic delivery systems

The key to fast freezing and fresher foods

Chilling, freezing, preservation and carbonation are just some of the ways cryogenic gases help preserve and transport foods and beverages. RegO flow control products are constructed for superior performance in demanding manufacturing environments.



NITROGEN INJECTION SYSTEMS FOR FOOD PRESERVATION AND FAST FREEZING

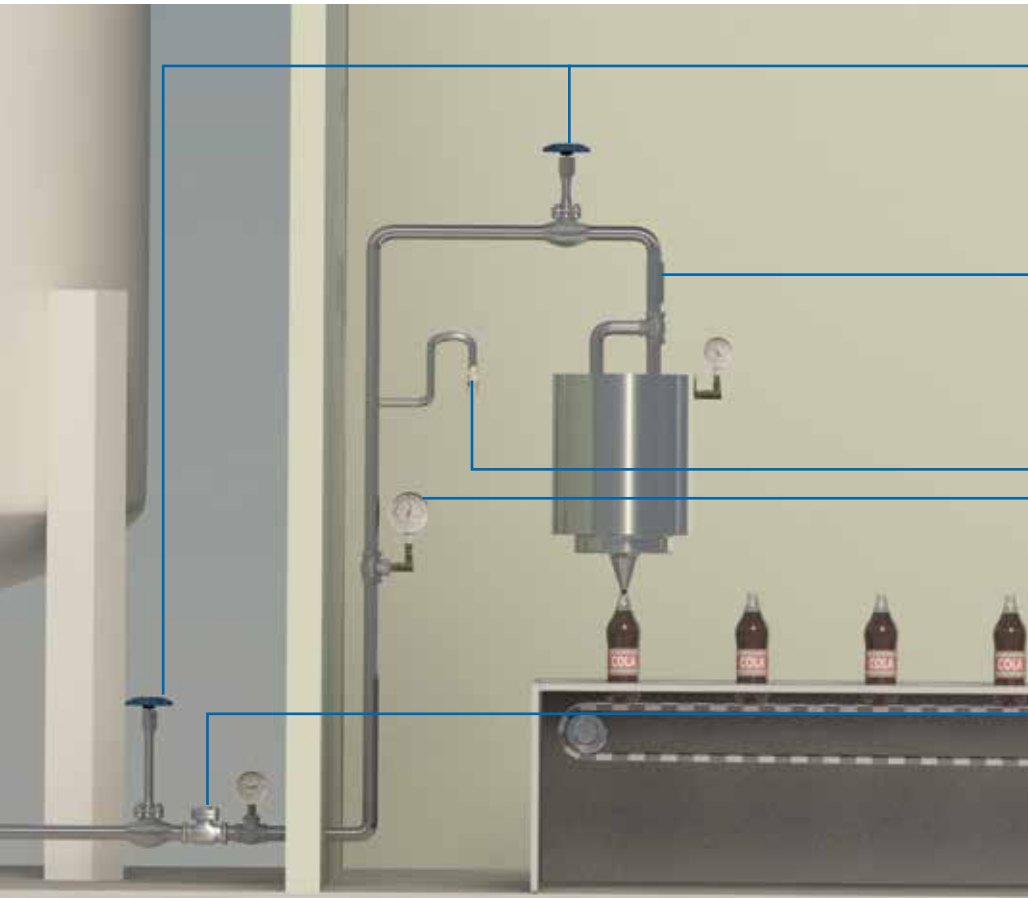

Gas phase regulation stations

On-demand use demands superior reliability

Durable RegO products provide years of efficient, low-maintenance gas flow from storage to application. In critical sectors such as healthcare, RegO quality can save money—and RegO reliability can save lives.

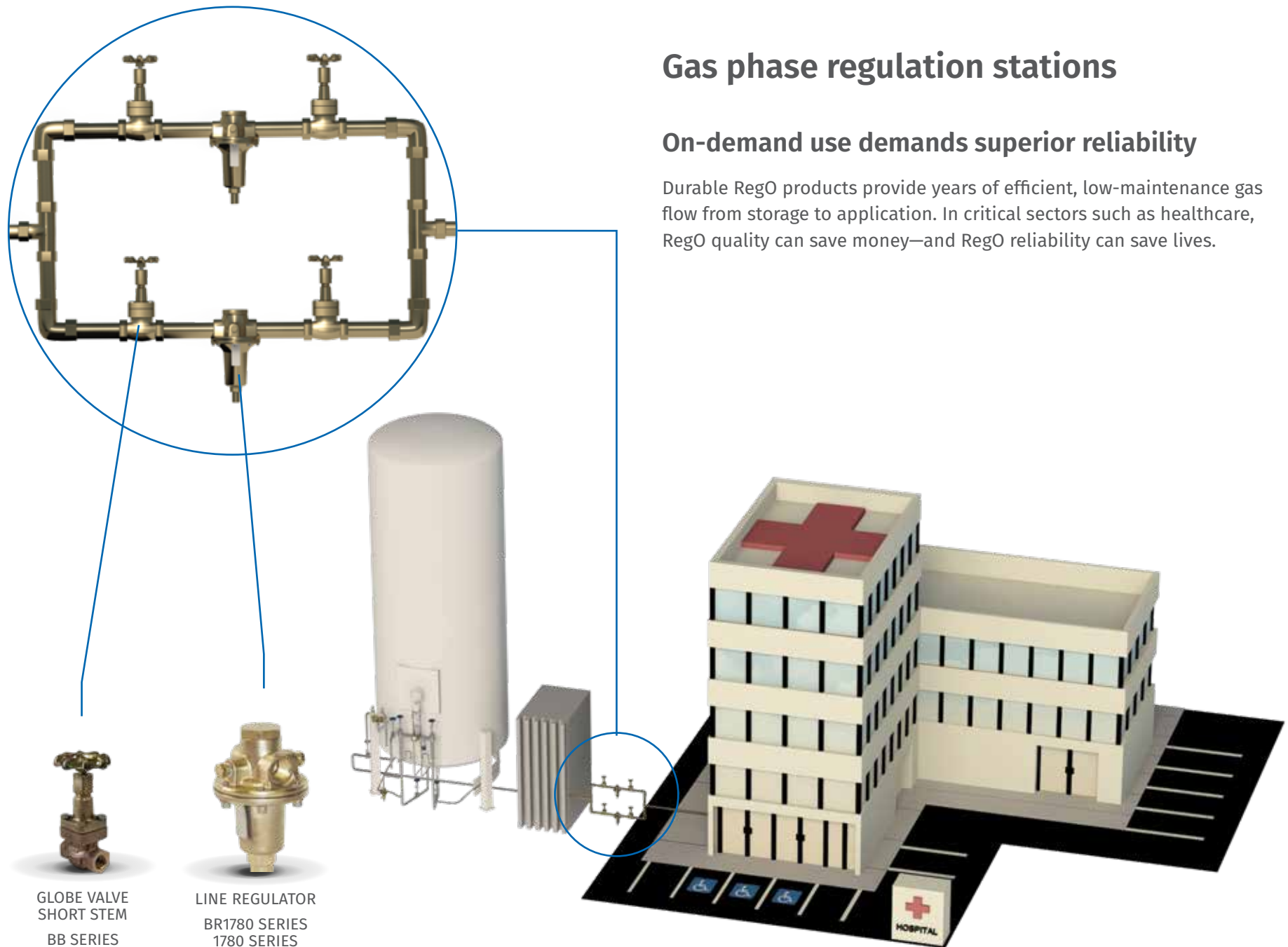

Electric transformer nitrogen delivery systems

Keep the power flowing with RegO

RegO Inertrol™ systems deliver the constant supply of nitrogen needed to provide an inert gas seal in transformer applications, and prevent oxidation and humidity in the transformer oil—extending the lifetime of the unit. Built to withstand the elements and to safely adjust for changes in temperature, RegO systems can be integrated to trigger alerts for unexpected changes in pressure.



INERTROL OUTFITS
4286, 4289, 4291 SERIES

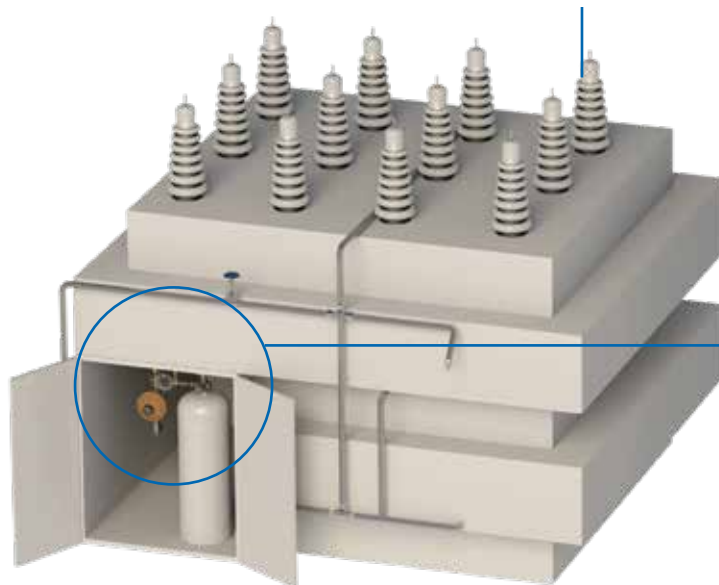

High pressure gas tube storage and transport

High pressure applications meet low maintenance solutions

Tube storage brings volume capabilities. A RegO valve brings years of safe, leak-free flow control to gas tube applications, as well as other high pressure manifold and piping systems. The HP9560 Series exhibits a very low operating torque under pressure for ease of manual operation.

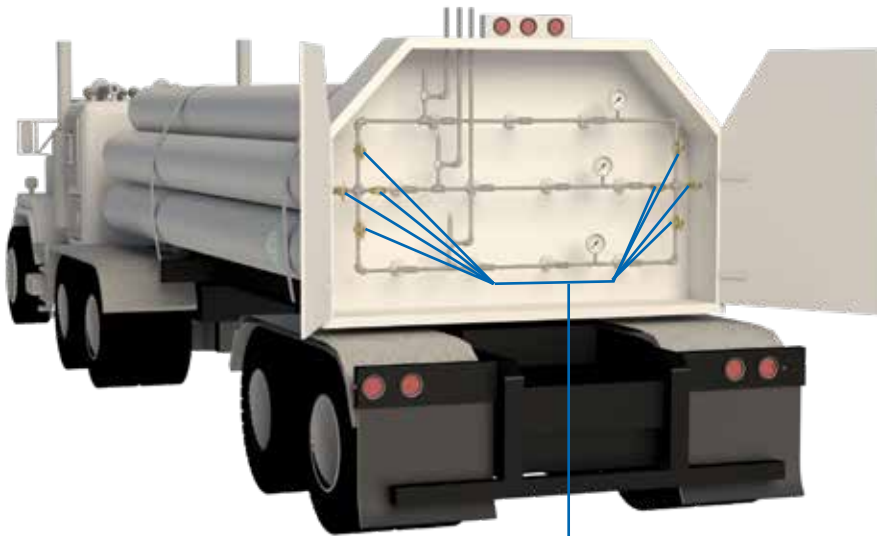

HIGH PRESSURE GAS
MASTER VALVE
HP9560 SERIES

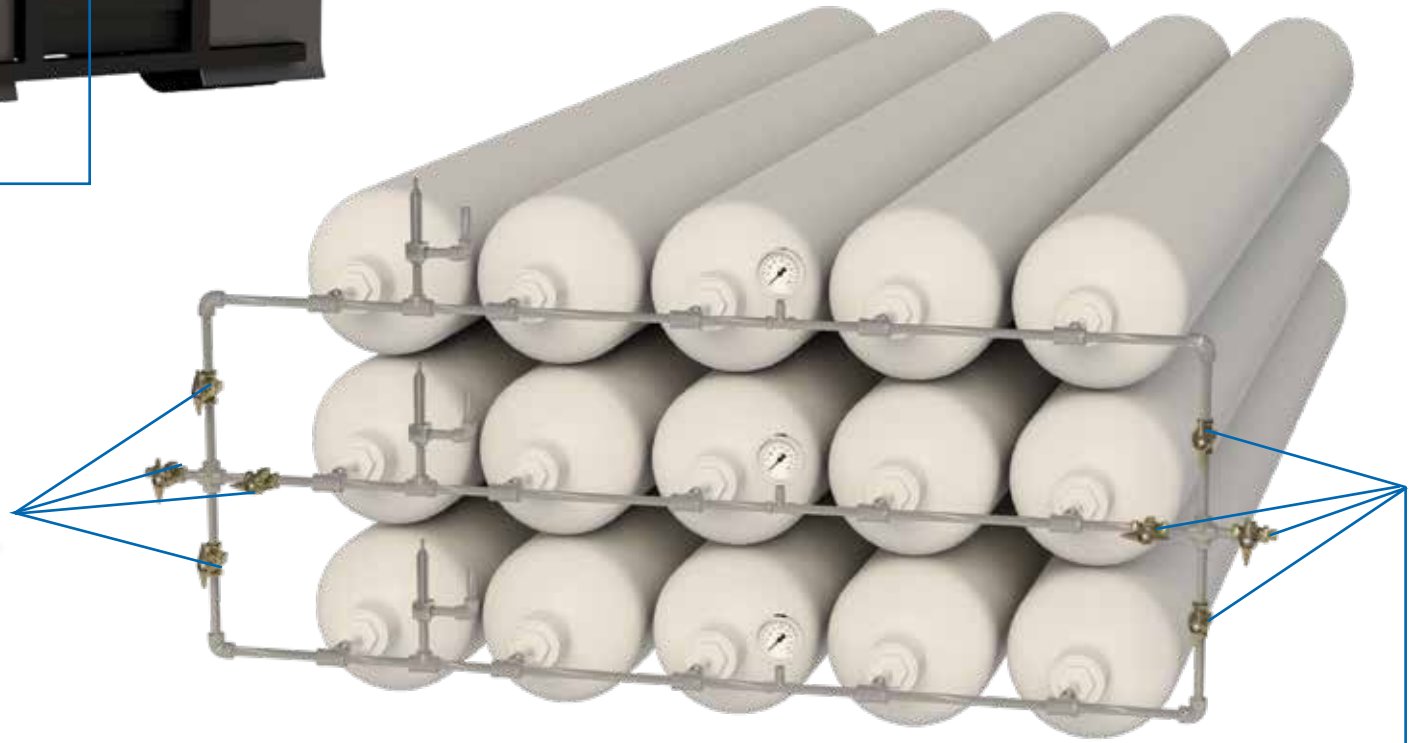

High and medium pressure manifold and delivery systems

We can handle all kinds of pressure

RegO has all the components you need to create your own system. Or you can tap our technical team's deep product and application knowledge and we will build to your specifications. Either way, you will get the benefit of RegO quality and innovation throughout to maintain steady pressure and excellent performance.

High pressure manifold and delivery systems

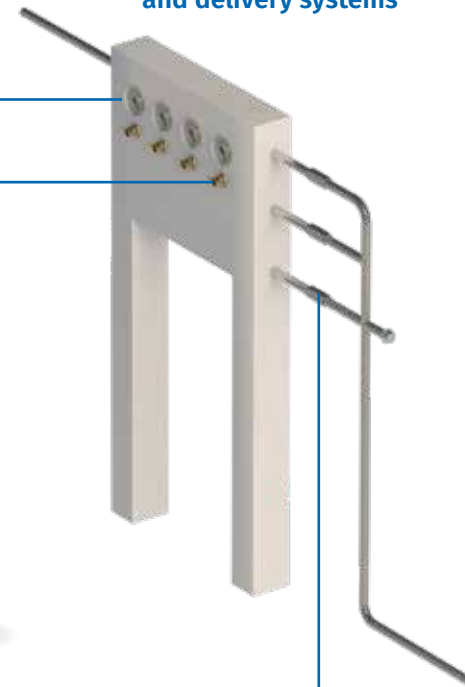

PRESSURE GAUGE
15578 SERIES

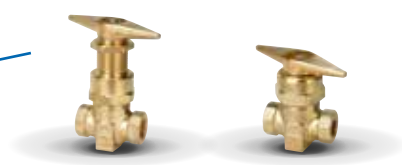

HIGH PRESSURE GAS MASTER VALVE
HP9560 SERIES

Medium and low pressure manifold and delivery systems

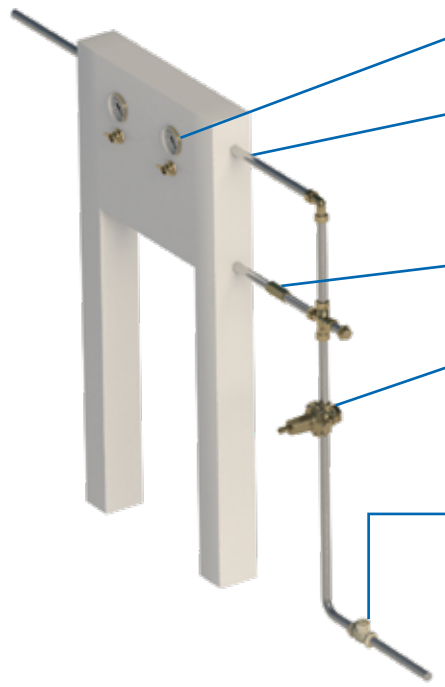

HORIZONTAL CHECK VALVE
8500 SERIES



LINE REGULATOR
BR 1780 SERIES
1780 SERIES



CHECK VALVE
CG SERIES

REGO ALSO OFFERS A COMPLETE SELECTION OF BRASS PIPE, ELBOWS TEES, CROSSES, CAPS AND PLUGS.

**COMPRESSED
GAS MANIFOLD
SYSTEMS**



Gas delivery systems

Reliable, on-demand industrial gas

RegO products manage gas for industrial applications, such as welding, cutting, heating and power generation. Through innovative design our products provide maximum reliability and precision to help fuel manufacturing processes and business profits.

REGO ALSO OFFERS A COMPLETE SELECTION OF BRASS PIPE, ELBOWS TEES, CROSSES, CAPS AND PLUGS.

Carbon dioxide delivery systems

We bring the “fizz” without the fuss

From the tank truck to the soda fountain, RegO products bring reliable, cost-effective carbon dioxide delivery—refill after refill.

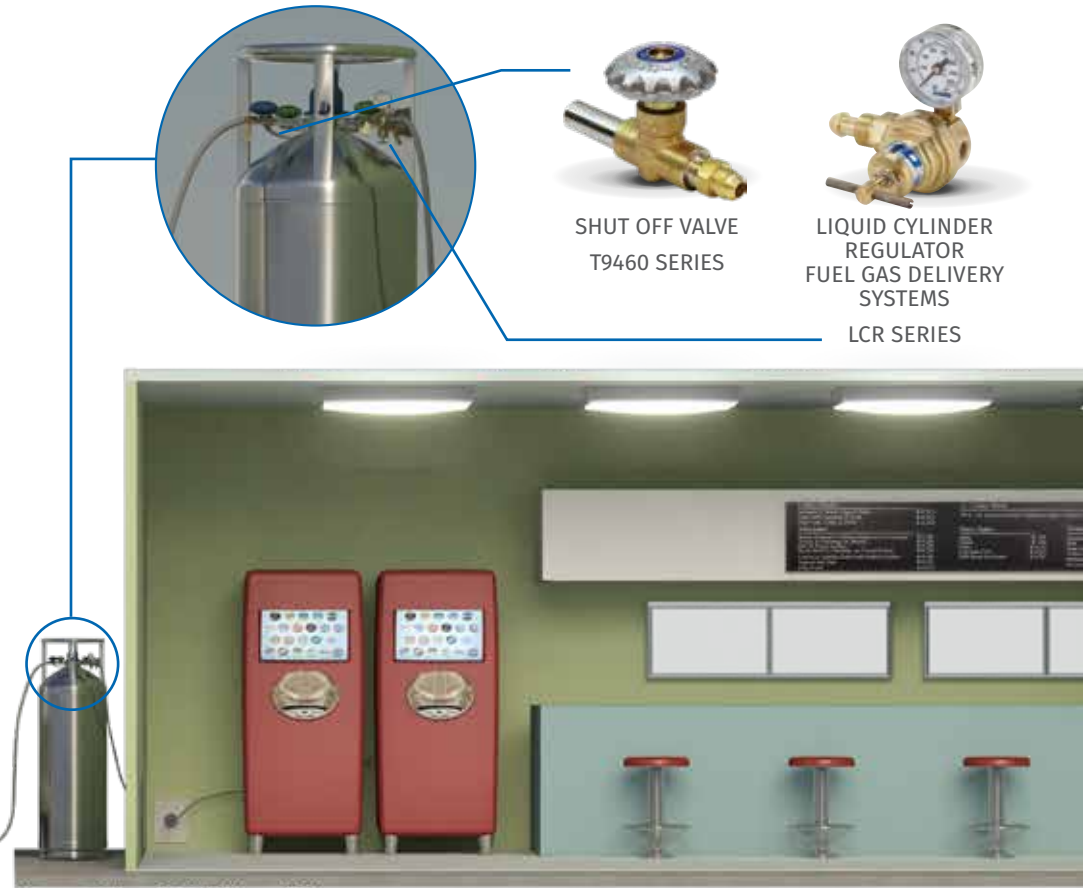

SHUT OFF VALVE
T9460 SERIES



LIQUID CYLINDER
REGULATOR
FUEL GAS DELIVERY
SYSTEMS
LCR SERIES

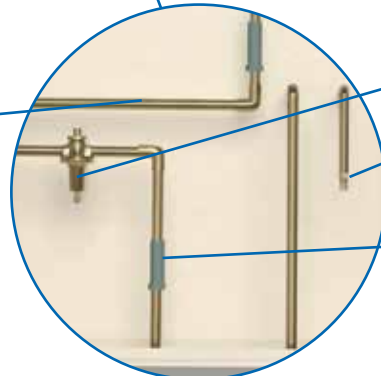

CARBON DIOXIDE
RELIEF VALVES
UA3149A SERIES



CHECK VALVE
CG SERIES



ASME RELIEF VALVE
C-19434B SERIES



LINE REGULATOR
BR1780 SERIES
1780 SERIES



PED Module D D1
 VdTUV Cryo Safety Valve
 VdTUV Cryo Shut Off Valve
 PED Module B Safety Valves
 TPED Cert AR NR PRV
 TPED Cert Cryo Shut Off
 SK Series TUV Cert 0036-068-17

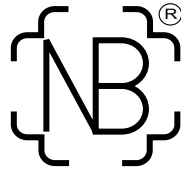
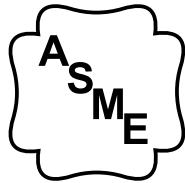

UV & NB



Conflict-Free Sourcing Initiative



OA7770_50346789NTY
 CRN OC15296_502346789NTY
 OC7770_502346789NTY
 OG7770_502346789NTY
 OH7770_5046789NTY
 OC8040_502346789NTY



Manufacturer License



ISO 9001:2015



KGSC Certificate

Product certifications

World-class quality—but do not just take our word for it.

RegO builds products that last. Our durable materials, proven designs, and rigorous testing, all add up to products designed for years of safe operation under hazardous conditions. With standards like these, it is no wonder that RegO quality is recognized the world over.

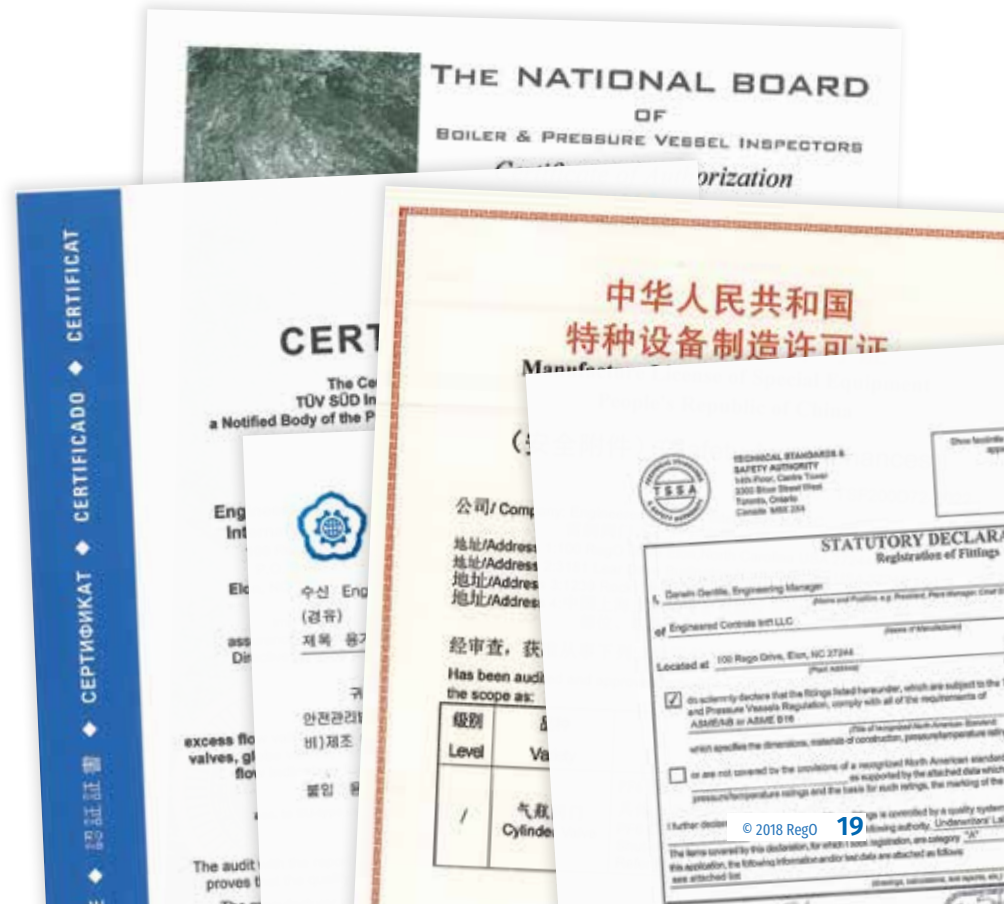



USA: Headquarters

Elon, NC USA
Phone: +1 336 449 7707
Email: ecii@regoproducts.com

Europe

Gladenbach, Germany
Phone: +49 6462 9147 10
Email: info@rego-europe.de

Latin America

Santa Catarina, Mexico
Phone: +52 81 8032 5250
Email: volalde@regoproducts.com.mx

Asia

Shanghai, China, 200131
Phone: +86 21 5046 2183,
+86 21 5046 2012
Email: david.wang@rego-asia.com



Quality materials, innovative, long-lasting design and operational excellence, are built into every product we manufacture. That is how we can offer a 10-year product warranty—double that of other companies.



Designed, manufactured and 100% tested in the USA. Our four state-of-the-art facilities build the products that are most critical to your application.

For technical assistance contact: support@regoproducts.com

regoproducts.com | rego-europe.de

RegO® is a registered trademark of Engineered Controls International, LLC
© 2018 RegO. All rights reserved. Unauthorized use will be prosecuted.

01-0518-0518