

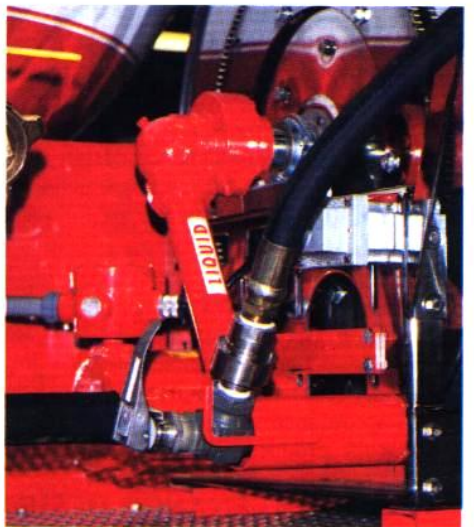

# SWIVEL CONNECTORS

*for thin to viscous liquids and liquefied gases*

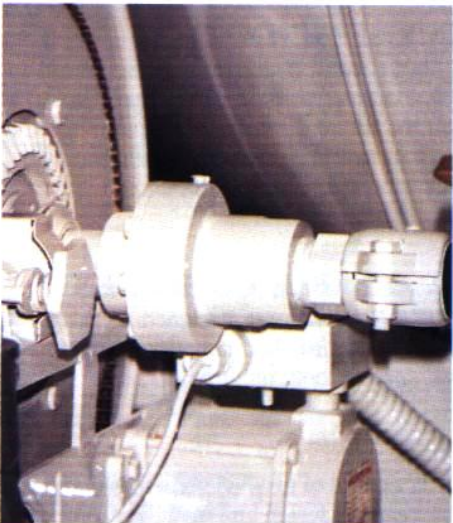

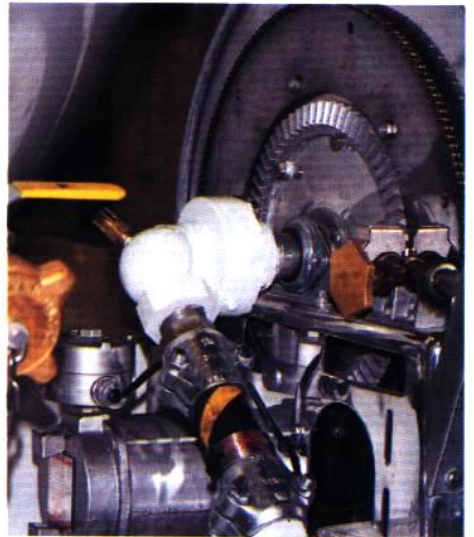
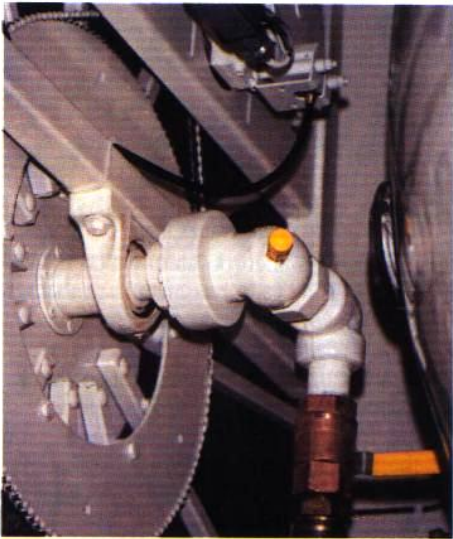
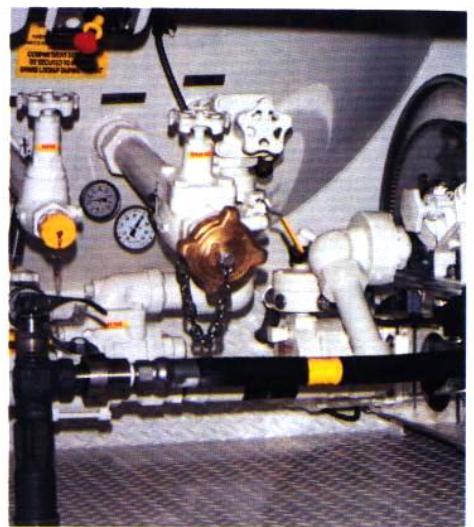

# DESIGN FEATURES

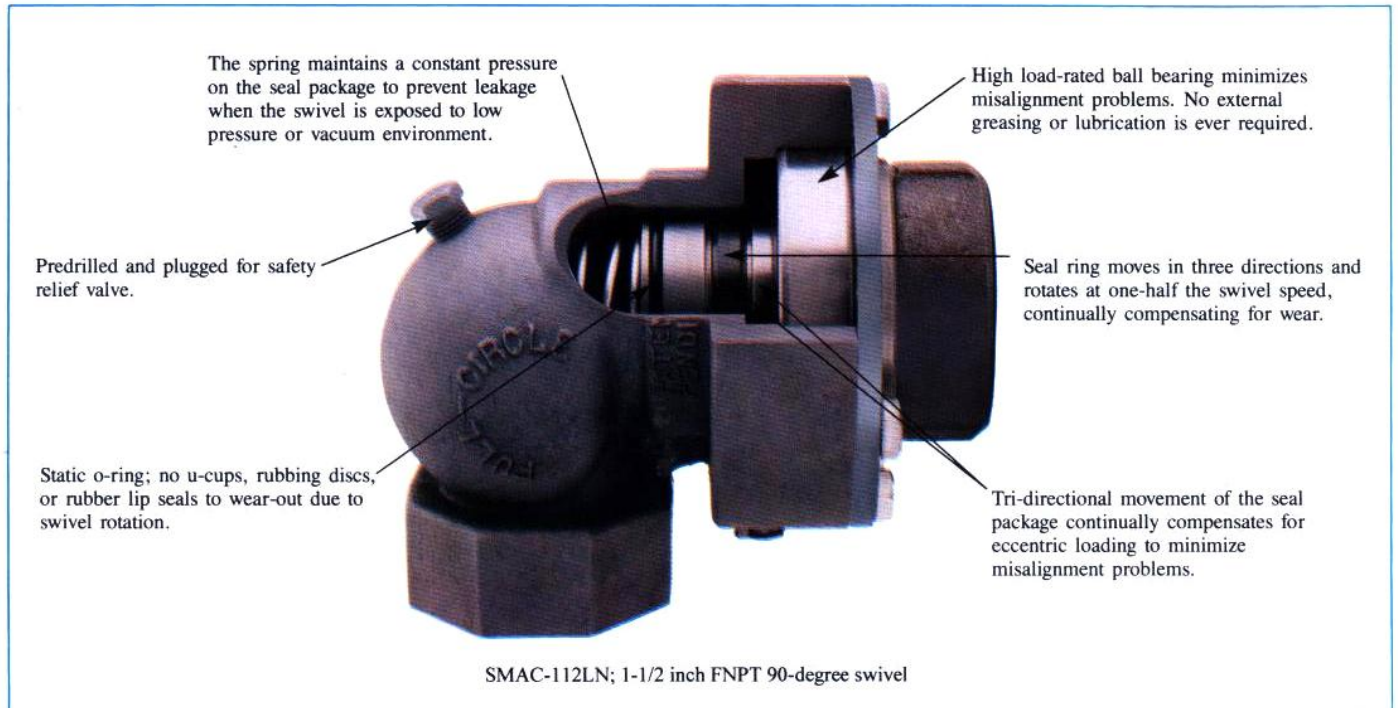

**FULL-CIRCLE** offers a complete line of swivel connectors designed for use with thin to viscous liquids and liquefied gases.

Straight-through hose end swivels allow the filler valve to rotate 360-degrees. This enables the driver to make tank connections without fighting the hose. It also prevents hose twisting upon reel-up.

For bulk-head use, the 90-degree swivel allows for the use of a shorter transfer hose and enables the operator to safely sweep the hose to one side for proper, out of the way stowage.

The design is ideally suited for hose reel use as the sealed high load ball bearing can tolerate misalignment problems that could cause product leakage in other swivel types. The tri-directional movement of the three-piece seal package continually compensates for eccentric movement.

The ZERO maintenance design is of critical importance, especially for loading/unloading arms that must be constructed high in the air for railroad tankcar transfer operations.

## SAFETY FIRST

All swivels produced by FULL-CIRCLE for LP-GAS, Ammonia, and Flammable liquids are Listed by the Underwriters Laboratories and are designed and tested in accordance with the U.L.-567 Standard, your assurance that the product has been tested to a Standard of Safety.

## NO MAINTENANCE DESIGN

All FULL-CIRCLE swivels utilize a sealed high load ball bearing. No greasing or lubrication is ever required.

## NO ROTATING RUBBER SEALS

All FULL-CIRCLE swivels incorporate the SUPERSEAL™ mechanical seal. This PATENTED design allows the seal ring to “float” between two metallic seals. While in operation, the seal ring rotates at one-half the swivel rotational speed. The tri-directional movement of the seal components allows for continuous adjustment due to vibration, misalignment, and temperature extremes. Upon depressurization, the seal spring maintains a constant force on the seal package, preventing product leakage in ZERO to low pressure environments.

## MISALIGNMENT MINIMIZED

All FULL-CIRCLE swivels utilize a radial contact ball bearing with extremely high load ratings. The bearing is sealed for life and requires NO periodic lubrication. The ball bearing completely supports the rotating portion of the swivel to ensure smooth and easy movement.

## FIELD REPLACEABLE COMPONENTS

All FULL-CIRCLE swivels are designed so that replacement parts can be installed simply and easily in the field with no special tools required.

## EXPERIENCE

FULL-CIRCLE's depth of product engineering is the result of over 65 years of design and manufacturing expertise in the high pressure, rotating equipment field, for thin liquids and liquefied gases.

# Hose Reel, Bulkhead, Loading Arm

## 90-Degree Type Swivels

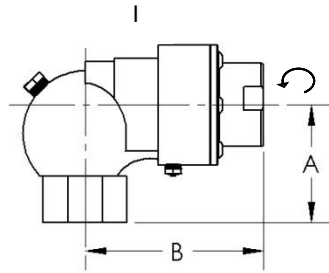

3/4", 1", & 1- 1/4" Type

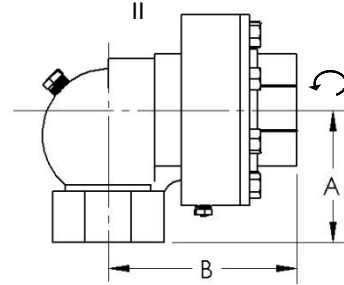

1- 1/2" & 2" Standard Type

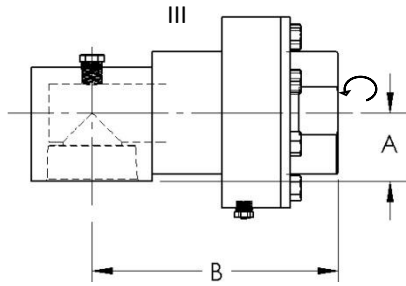

1- 1/2" & 2" Stainless Steel Type

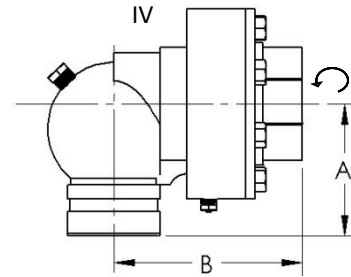

1- 1/2" & 2" Victaulic Type

All dimensions in inches  
All weights in pounds  
All threads NPT

MODEL	Illustration	SIZE*	A	B	WEIGHT
SMAC-3490LN	I	3/4 X 3/4	3	4- 5/8	6- 3/4
SMAC-190LN	I	1 X 1	3	4- 5/8	6- 3/4
SMAC-114LN	I	1- 1/4 X 1- 1/4	3	4- 5/8	6- 3/4
SMAC-112LN	II	1- 1/2 X 1- 1/2	3- 1/4	4- 3/4	13- 1/8
SMAC-200LN	II	2 X 2	3- 1/4	4- 3/4	13- 1/8
SMAC-112SS	III	1- 1/2 X 1- 1/2	1- 3/4	6- 9/32	15- 1/2
SMAC-200SS	III	2 X 2	1- 3/4	6- 9/32	15- 1/2
SMAC-34190LN	I	3/4 X 1	3	4- 5/8	6- 3/4
SMAC-190340LN	I	1 X 3/4	3	4- 5/8	6- 3/4
SMAC-34114LN	I	3/4 X 1- 1/4	3	4- 5/8	6- 3/4
SMAC-114340LN	I	1- 1/4 X 3/4	3	4- 5/8	6- 3/4
SMAC-190114LN	I	1 X 1- 1/4	3	4- 5/8	6- 3/4
SMAC-114190LN	I	1- 1/4 X 1	3	4- 5/8	6- 3/4
SMAC-112200LN	II	1- 1/2 X 2	3- 1/4	4- 3/4	12- 3/4
SMAC-200112LN	II	2 X 1- 1/2	3- 1/4	4- 3/4	12- 3/4
SMAC-112200SS	III	1- 1/2 X 2	1- 3/4	6- 9/32	15- 1/4
SMAC-200112SS	III	2 X 1- 1/2	1- 3/4	6- 9/32	15- 1/4
SMAC-2V112FC**	IV	2 X 1- 1/2	3- 1/4	4- 3/4	12- 1/2
SMAC-2V200FC**	IV	2 X 2	3- 1/4	4- 3/4	12- 1/2

For Combination threads, (Inlet X Outlet), Rotating End is Outlet

↻ Designates Rotating End

\*All threads are female

\*\*Victaulic swivels are intended for gasoline, kerosene, fuel oils, and diesel fuels not exceeding 50 psi. Threads are located on rotating end of swivel.

# Hose Reel, Bulkhead, Loading Arm

## Straight-Through Type Swivels

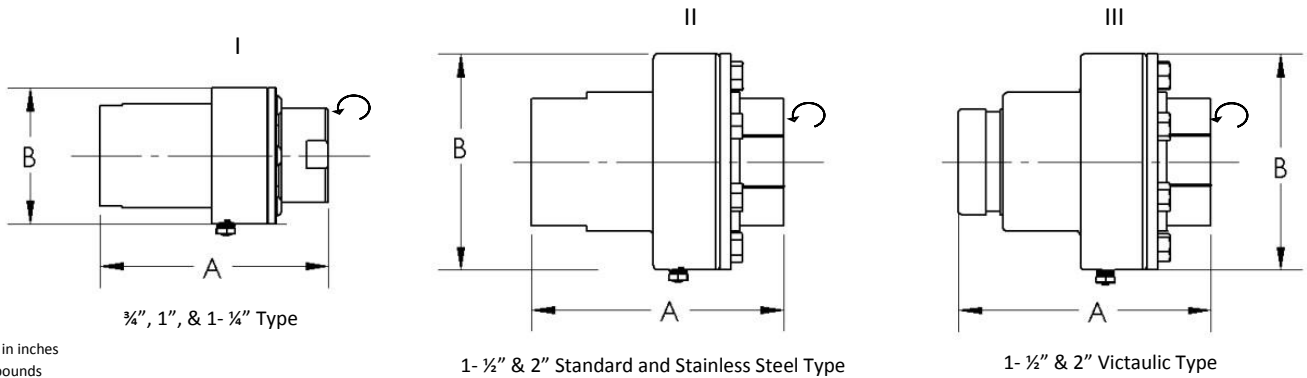

All dimensions in inches  
All weights in pounds  
All threads NPT

MODEL	Illustration	SIZE*	A	B	WEIGHT
SMAC-34STLN	I	3/4 X 3/4	5- 1/4	3- 1/16	4- 1/2
SMAC-1STLN	I	1 X 1	5- 1/4	3- 1/16	4- 1/2
SMAC-114STLN	I	1- 1/4 X 1- 1/4	5- 1/4	3- 1/16	4- 1/2
SMAC-112STLN	II	1- 1/2 X 1- 1/2	5- 11/16	4- 7/8	11- 3/4
SMAC-200STLN	II	2 X 2	5- 11/16	4- 7/8	11- 3/4
SMAC-112STSS	II	1- 1/2 X 1- 1/2	5- 11/16	4- 7/8	11- 3/4
SMAC-200STSS	II	2 X 2	5- 11/16	4- 7/8	11- 3/4
SMAC-341STLN	I	3/4 X 1	5- 1/4	3- 1/16	4- 1/2
SMAC-1340STLN	I	1 X 3/4	5- 1/4	3- 1/16	4- 1/2
SMAC-34114STLN	I	3/4 X 1- 1/4	5- 1/4	3- 1/16	4- 1/2
SMAC-11434STLN	I	1- 1/4 X 3/4	5- 1/4	3- 1/16	4- 1/2
SMAC-1114STLN	I	1 X 1- 1/4	5- 1/4	3- 1/16	4- 1/2
SMAC-1141STLN	I	1- 1/4 X 1	5- 1/4	3- 1/16	4- 1/2
SMAC-112200STLN	II	1- 1/2 X 2	5- 11/16	4- 7/8	11- 1/2
SMAC-200112STLN	II	2 X 1- 1/2	5- 11/16	4- 7/8	11- 1/2
SMAC-112200STSS	II	1- 1/2 X 2	5- 11/16	4- 7/8	11- 1/2
SMAC-200112STSS	II	2 X 1- 1/2	5- 11/16	4- 7/8	11- 1/2
SMAC-2V112STFC**	III	2 X 1- 1/2	5- 11/16	4- 7/8	11- 1/2
SMAC-2V200STFC**	III	2 X 2	5- 11/16	4- 7/8	11- 1/2

For Combination threads, (Inlet X Outlet), Rotating End is Outlet

↻ Designates Rotating End

## Hose End (allows filler valve to rotate 360-degrees)

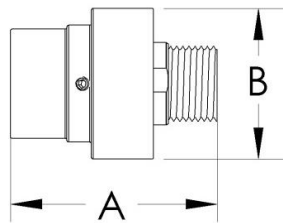

MODEL	SIZE	THREADS	A	B	WEIGHT
JO-34	3/4 X 3/4	FEMALE X MALE	3- 3/8	2- 1/2	1- 1/2
JO-1	1 X 1	FEMALE X MALE	3- 3/8	2- 1/2	1- 1/2
JO-114	1- 1/4 X 1	FEMALE X MALE	3- 3/8	2- 1/2	1- 1/2

\*All threads are female

\*\*Victaulic swivels are intended for gasoline, kerosene, fuel oils, and diesel fuels not exceeding 50 psi. Threads are located on rotating end of swivel.

**APPLICATION:**

For loading/unloading arm such as a railroad tankcar loading/unloading operation where swivel action in two different planes is required. Combinations shown are shipped assembled for 1- inch male counterbalance.

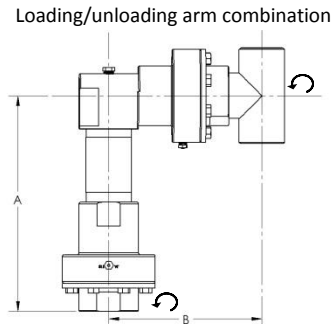

**LOADING/UNLOADING ARM COMBINATION**

MODEL	SIZE	THREAD	A	B	WEIGHT
SMAC-112LA	1- 1/2 X 1- 1/2	FEMALE X FEMALE	9- 1/2	11	38
SMAC-200LA	2 X 2	FEMALE X FEMALE	9- 1/2	11	38

All dimensions in inches  
All weights in pounds

**Model Number Explanation**

SMAC prefix symbol model numbers shown in the catalogue may end with the letters LN. The letters at the end of the model number categorize the swivel according to the liquid/liquefied gas it is designed for. For other liquids/liquefied gases, please refer to the table below to determine the correct model number by adding the appropriate letters to the end of the model number.

Recommended for	Letters at end of SMAC-series model number				
	LN	N	SS	FC	LA
<b>LP- Gas, Natural Gas</b>	X				
<b>Anhydrous Ammonia</b>		X			
<b>LP-Gas, Natural Gas, Refined Fuels</b>			X*		X*
<b>Refined Fuels Only</b>				X	
<b>Other liquids/liquefied gases</b>	Contact our engineering department				

\*SS option swivels contain corrosion resistant materials recommended where swivel may be exposed to moisture-laden air or systems routinely blown down; cannot be used for Anhydrous Ammonia. Loading arm combinations are SS type swivels. After selecting the correct model swivel for type of liquid/liquefied gas, add letters SS to the end of model number.

Refined Fuels include heating oil, jet fuel, gasolines, and diesel fuels.

JO-series swivels shown in catalogue are for LP-GAS. Add letters LN to end of model number for Anhydrous Ammonia and FC for refined fuels.

Temperature range: -40 °F to +250 °F

Hydrostatic test Pressure: 2000 psi

Maximum Working Pressure: 400 psi

Approvals: U.L. listed for LP-Gas, Anhydrous Ammonia, Natural Gas, and Refined Fuels in Accordance with U.L.-567 Standard. Most swivel models comply with the following European Directives: Pressure Equipment, Machinery, and ATEX. EC Declarations of Conformity and/or Declaration of Incorporation are available upon request.



## QUICK-VENT™ Vent Devices



The Quick-Vent products are designed to safely and efficiently purge, evacuate, or isolate a meter or other equipment in the pipework.

Available for 2", 1" or ¾" flanged version to replace the blind strainer screen on a meter casing. Also available in ¾" NPT version for installation in a tee for a convenient location in the pipework.

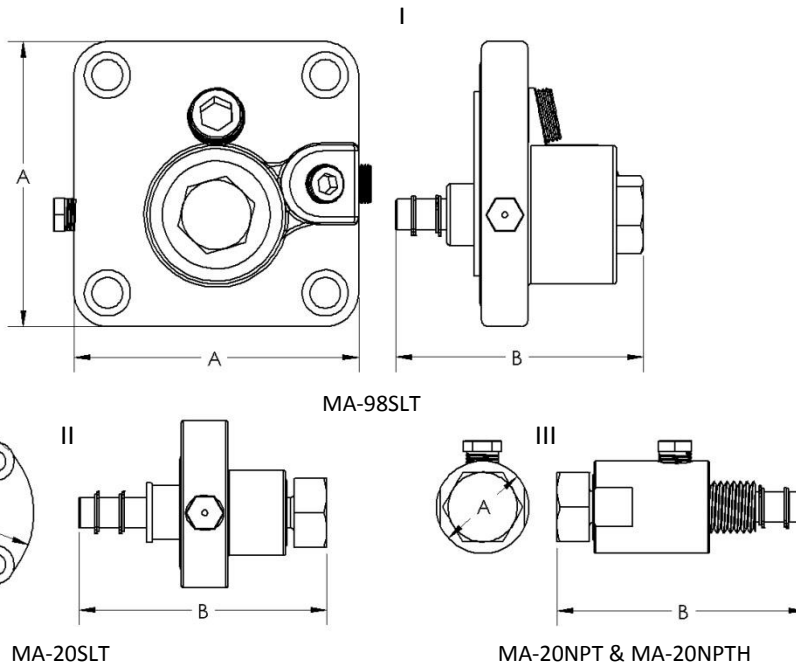

All dimensions in inches  
All weights in pounds  
All threads NPT

MODEL	ILLUSTRATION	METER SIZE	A	B	WEIGHT
MA-98SLT	I	2	4- <sup>5</sup> / <sub>8</sub>	3- <sup>7</sup> / <sub>8</sub>	6
MA-20SLT	II	¾ & 1	3	3- <sup>7</sup> / <sub>8</sub>	2
MA-20NPT	III	¾ (THREAD SIZE)	1- <sup>1</sup> / <sub>2</sub>	3- <sup>7</sup> / <sub>8</sub>	1
MA-20NPTH*	III	¾ (THREAD SIZE)	1- <sup>1</sup> / <sub>2</sub>	3- <sup>7</sup> / <sub>8</sub>	1

\*MA-20NPTH includes a port for hydrostatic relief application